

Elite Shower Base



 **Made in the USA**

ITEM ID#	COLOR*	DESCRIPTION	DIMENSIONS	SHIPPING WEIGHT
0377937	W	Elite Shower Base	32" x 32" x 3½" Center	24 lbs
0377939	B			
0377991	W	Elite Shower Base	36" x 36" x 3½" Center	26 lbs
0377992	B			
0378050	W	Elite Shower Base	48" x 34" x 3½" Center	30 lbs
0378051	B			
0378090	W	Elite Shower Base	60" x 32" x 3½" Left	34 lbs
0378074	B			
0378071	W	Elite Shower Base	60" x 32" x 3½" Right	34 lbs
0378073	B			
0378091	W	Elite Shower Base	60" x 34" x 3½" Center	34 lbs
0378093	B			

***COLOR OPTIONS: W = WHITE B = BISCUIT**

FEATURES

- High gloss acrylic surface
- Reinforced with fiberglass and OSB for maximum support
- Scratch and stain resistant
- Spacious slip resistant area
- Flange screws direct-to-stud, no predrilling or clips required
- Covered with protective film to maintain finish and protect during installation
- 100% Robotic spraying improves quality and consistency
- 5-year consumer, 2-year commercial limited warranty
- Meets ANSI and CSA standards

Contact Your Blevins Sales Representative For More Information
www.BLEVINSINC.com

Blevins

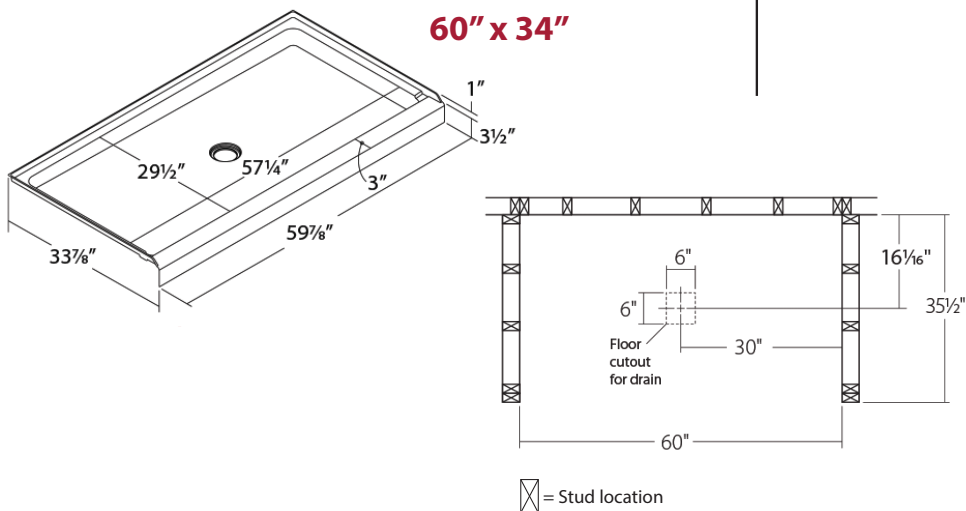
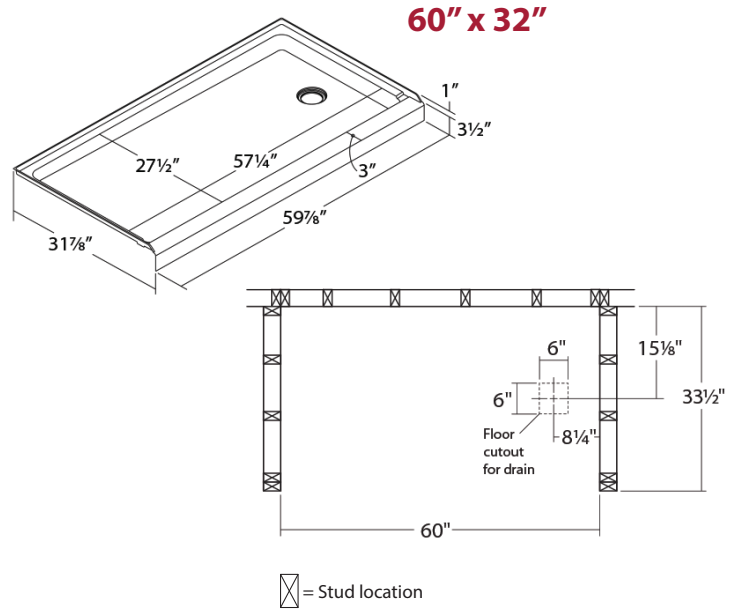
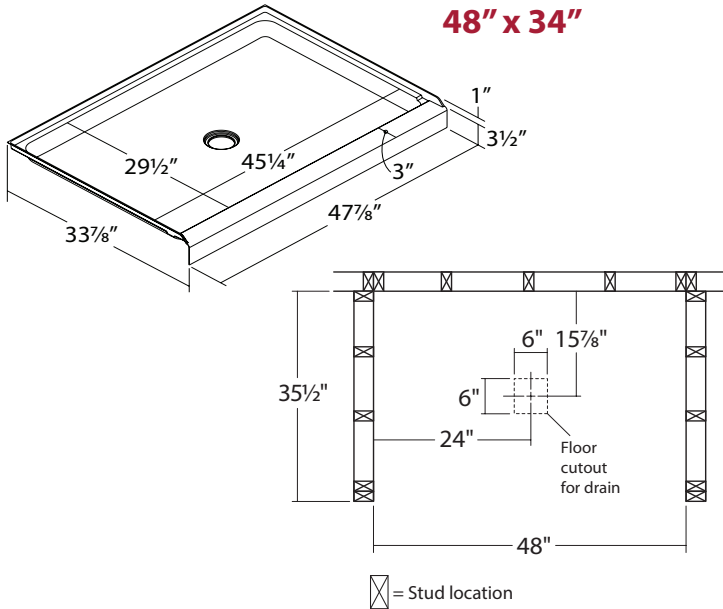
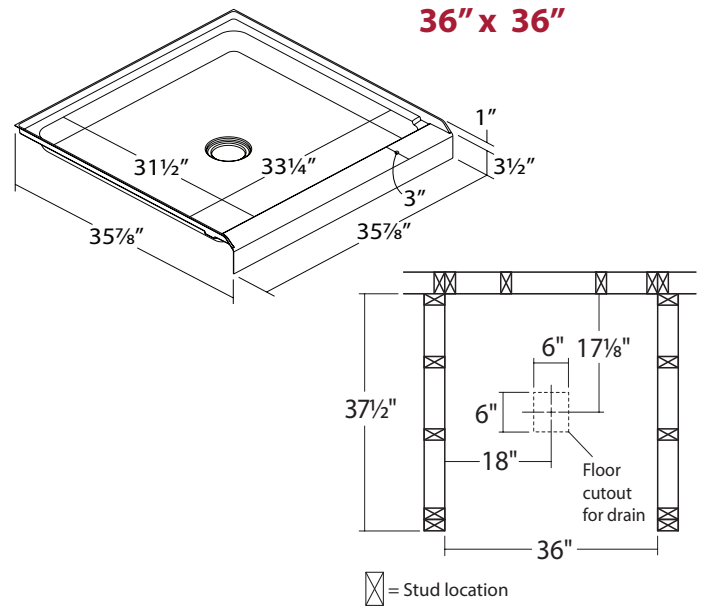
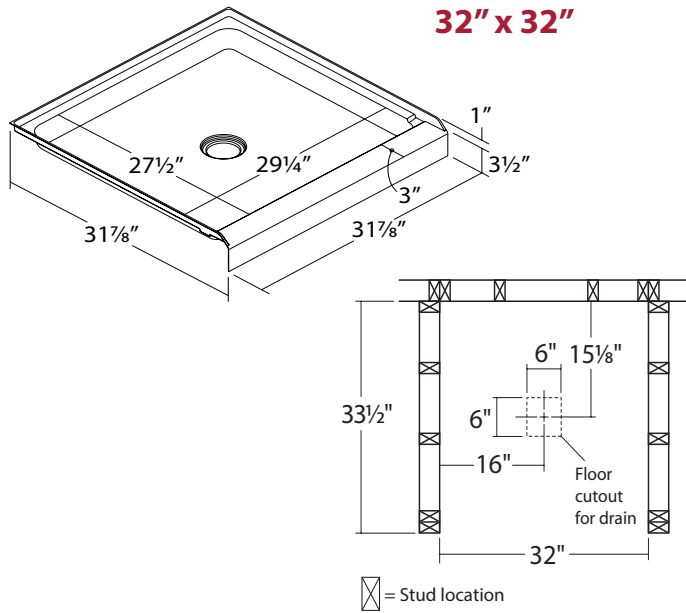

* Color shown may vary slightly from the actual product due to variations in the printing process of this document.

** Plumbing accessories not included.

Design and features may change without notice.

Complies with ANSI Z124.1 and CAN/CSA-B45

CAN/ULC S102.2 Flame-75 & Smoke Developed-485 code.

Complies with ASME:A112.19.7 and CAN/CSA-B45.10

All product subject to manufacturing tolerance of [+] or [-] 1/8".

Printed in U.S.A.

11-2018

L06